

# Town of Colchester, Connecticut

127 Norwich Avenue, Colchester, Connecticut 06415

## HISTORIC DISTRICT COMMISSION

### Special Meeting

Monday, January 11, 2021

7:00 P.M.

Virtual Meeting to be held via ZOOM. For a link to the ZOOM meeting please visit the Town of Colchester Public Meetings Calendar at [www.colchesterct.gov](http://www.colchesterct.gov).

### AGENDA

1. Call to Order
2. Additions to Agenda
3. Minutes of Previously Held Meeting: December 21, 2020
4. Five Minute Session for Public
5. Public Hearings:
  - A. Town Green Improvement Project – Certificate of Appropriateness (2020-02) To implement the improvements of the Community Connectivity Program grant including renovation of the main path, erection of a new bus shelter and installation of new lights, benches and trash receptacles on the Town Green.
6. New Applications:
7. Old Business
8. New Business:
  - A. Town Green Improvement Project – Certificate of Appropriateness (2020-02) To implement the improvements of the Community Connectivity Program grant including renovation of the main path, erection of a new bus shelter and installation of new lights, benches and trash receptacles on the Town Green.
9. Communications
10. Adjournment

RECEIVED  
COLCHESTER, CT  
2021 JAN -8 PM 1:08  
Aylee Fierman  
TOWN CLERK



# *Town of Colchester, Connecticut*

127 Norwich Avenue, Colchester, Connecticut 06415

---

## **HISTORIC DISTRICT COMMISSION**

**Monday, December 21, 2020**

**7:00 P.M.**

**Meeting held via ZOOM**

**Meeting Minutes**

**Members Present: Ellen Sharon, Chair; Linda Akerman, Vice-Chair; Theresa Congdon, Robert Kverderas; Stanley Stefanowicz, Janice Adams (alternate), Lindsey Floyd (alternate), Janice Adams (alternate)**

**Board of Selectman Liaison: Denise Turner**

**Staff: Matthew Bordeaux, Planning Director**

1. Call to Order – The meeting was called to order at 7:00 p.m.
2. Additions to Agenda – There were no additions to the Agenda
3. Minutes of Previously Held Meeting: October 19, 2020 (Special Meeting)  
*Mr. Kverderas moved to approve the meeting minutes of October 19, 2020. Ms. Akerman seconded the motion. Ms. Akerman noted her name was misspelled under item #10. The minutes were approved unanimously.*
4. Five Minute Session for Public: Ms. Sharon asked Mr. Bordeaux to provide an overview of the new application for improvements on the Town Green so that the public would have an opportunity to comment since the Agenda did not include the item listed as a public hearing.

Mr. Bordeaux described the project, the grant program, process and proposed improvements. The improvements consist of the improvement of the main path and in the installation of ancillary paths; the erection of a new bus shelter; the installation of lights, benches and trash receptacles; the replacement of the community events board; and the replacement of electrical utility shed located adjacent the gazebo. Mr. Bordeaux requested that improvements of the gazebo be considered as a follow-up to the current proposal.

Ms. Sharon opened the meeting to the public and requested that comments be directed toward each improvement in sequence. Public comments included an emphasis on the importance of regular maintenance, the poor condition of the main path; the possibility of reducing the number of benches. Mr. Andrew Norton conveyed the opinion of the Bacon Academy Board of Trustees. Mr. Greg Barden expressed the importance of the electrical outlets proposed to be installed in the base of the light posts to the various user groups and event participants on the Green throughout the year.

The Commission also reviewed and commented on each proposed improvement in sequence. There was general favor for the proposed 4-sided light, renovation of the main path, and bus shelter. The Commission was generally opposed to the proposal for the new connecting path to Hayward Avenue as it would interrupt the green space between the ball field and the gazebo. The Commission requested additional information for the next meeting.

5. Public Hearings: None

6. New Applications:

- A. Town Green Improvement Project – Certificate of Appropriateness (2020-02) – To implement the improvements of the Community Connectivity Program grant including renovation of the main path, erection of a new bus shelter and installation of new lights, benches and trash receptacles on the Town Green.

7. Old Business: None

8. New Business:

- A. 2021 Meeting Calendar

*Ms. Congdon moved to approve the 2021 Meeting Calendar as drafted. Ms. Akerman seconded the motion. The calendar was approved unanimously.*

- B. Election of Officers

*No new nominations were proposed. Mr. Kverderas moved to close the nominations. Mr. Stephanowicz seconded the motion. The motion carried unanimously.*

*Ms. Congdon moved to re-elect Ms. Sharon as Chair, Ms. Akerman as Vice-Chair, and Mr. Kverderas as Secretary. Mr. Stephanowicz seconded the motion. The motion carried unanimously.*

9. Communications: None

**10.** Adjournment –

*Ms. Congdon made a motion to adjourn the meeting at 9:40 p.m. Motion was seconded by Ms. Akerman. The motion carried unanimously.*

**TOWN OF COLCHESTER  
LEGAL NOTICE**

The Historic District Commission will hold a virtual public hearing on January 11, 2021, at 7:00 P.M. to hear and consider the following petitions:

1. **Town Green Improvement Project – Certificate of Appropriateness (2020-02)** – To implement the improvements of the Community Connectivity Program grant including renovation of the main path, erection of a new bus shelter and installation of new lights, benches and trash receptacles on the Town Green.

At this hearing interested persons may be heard and written communications received. A copy of this petition is in the Planning and Zoning Department, Town Hall, 127 Norwich Avenue, and may be inspected during regular business hours (8:30 a.m. – 4:30 p.m., Monday through Friday).

Historic District Commission  
Ellen Sharon, Chair



Town of Colchester, Connecticut  
HISTORIC DISTRICT COMMISSION

APPLICATION FOR CERTIFICATE OF APPROPRIATENESS

Application Number COA 2020-02

Application Date 12/4/2020

Address of Proposed Work Town Green - Hayward Avenue

Owner Town of Colchester / Trustees + Proprietors of Bacon Academy Telephone \_\_\_\_\_

Applicant Town of Colchester Planning + Zoning Dept. Telephone 860-537-7282

Applicant's Address 127 Hayward Avenue, Colchester, CT

Agent or Contractor Matthew Bordeaux, Planning Director Telephone 860-537-7282

General Description of Proposed Work:

Colchester Town Green Bicycle and Pedestrian Improvement Project  
see description attached

List of Materials to be Used:

see list of materials attached

List of Attached Exhibits:

see list of exhibits attached

It is recommended that the applicant review the information contained in the Colchester Historic District Commission Handbook prior to filing an application to review necessary regulations and guidelines. The applicant should submit plans, photographs, drawings or other such exhibits to aid the Commission in its evaluation of the application.

Math R. Bordeaux

Signature of Applicant

RECEIVED  
TOWN OF COLCHESTER  
COMMUNITY DEVELOPMENT DEPARTMENT  
2020 DEC -4 AM 11:48

This is to certify that Application Number COA2020-2 dated 12/4/20 and supporting exhibits thereto for premises located at Town Green - Hayward Ave were received and were available for public inspection prior to the Public Hearing to be held on 12/21/2020.

Date 12/4/2020

Signed Daphne C. Schumb  
Clerk, Town of Colchester



FOR HISTORIC DISTRICT COMMISSION ONLY

Date of Legal Notice: \_\_\_\_\_

Date of Public Hearing: \_\_\_\_\_

\_\_\_\_\_ Application approved as submitted

\_\_\_\_\_ Application approved as modified below

\_\_\_\_\_ Application rejected

\_\_\_\_\_ Certificate of Appropriateness not required

Comments:

Expiration Date of Certificate \_\_\_\_\_

Date \_\_\_\_\_

Signed \_\_\_\_\_

Chairman, Historic District Commission

Application for Certificate of Appropriateness

Address of Proposed Work: Town Green

Owner: Trustees + Proprietors of Bacon Academy / Town of Colchester

Applicant: Town of Colchester Planning and Zoning Department

General Description of Proposed Work:

On January 18, 2019, the Town of Colchester was awarded a \$397,000 grant under the Community Connectivity Grant Program by the State Department of Transportation. The program initiative is to improve accommodations for bicyclists and pedestrians in community centers. These community centers serve as a place where people can meet for social, educational, employment and recreational activities. The goal of the Program is to make conditions safer and more accommodating for pedestrians and cyclists, thereby encouraging more people to use these healthy and environmentally sustainable modes of travel.

The project consists of the improvement of the main path and associated enhancements such as new, pedestrian-scale lighting running parallel to the main path, new park benches, trash receptacles, a new bus shelter and new paths to provide key connections within the park.

The main path will be reconditioned for a uniform width and graded to drain appropriately. This means that the surface material will be stripped and reused, or a new stone dust will be spread and rolled into an improved subbase of processed gravel. Either way, the result is intended to mimic the existing condition. The improved subbase will be installed to an engineered standard (depth and composition) intended to handle the volume and type of traffic seen throughout the year. The edges will be restored with topsoil and grass seed and graded to blend naturally into the existing turf.

To improve circulation on the Green, particularly during events that permit or necessitate vehicle traffic within the park, a new section of path, of the same material and dimension as the existing main path, is proposed to make a connection from the main path to Hayward Avenue. This will accommodate a one-way circulation of vehicle traffic and reduce the uncertainty of where vehicles may be traveling while pedestrians are present. The location of the proposed "new" connection is depicted on the site plan in the vicinity of an historic path that once crossed the park from east (Hayward Avenue) to west (Main Street).

The new light posts will line both sides of the main path and be staggered at a uniform distance for a formal, intentional look. Associated with each new light post, a park bench will be set off approximately four (4) feet from the path. Each bench would be mounted to an appropriate footing set just below grade and the ground surface treated to be consistent with the main path. New trash receptacles will replace the existing barrels and be distributed, as appropriate, across the Green.

A new bus shelter is proposed to replace the one destroyed in an automobile accident (see "Proposed Bus Shelter and Information Kiosk" prepared by William Brewster Architects, attached). The attached rendering is intended to depict the form only. The new shelter will be framed with wood (not PVC or aluminum as noted), either pressure-treated or a species resilient to outdoor exposure such as cedar or cypress. The majority of the wall space will be glass to allow natural light to enter, providing 360-degree

visibility for safety and security reasons. The roof will include a bell-shaped design, taking cues from the existing gazebo on the Green, and be completed with architectural asphalt shingles.

As depicted on the site plan prepared by Anchor Engineering Services, the bus shelter will be shifted from its current position to better line up with the existing pull-off on Main Street intended to allow the CT Transit commuter bus to move safely out of the lane of traffic. A pedestrian path will be constructed from the existing, signalized crosswalk on Main Street to the bus shelter, with a short stem connection to the Main Path. These proposed ancillary connections will be approximately six (6) feet wide and of the same material as the main path.

Additional improvements will include the replacement, in kind, of the Colchester Community Events board located at the corner of Norwich Avenue and Main Street. The electrical utility shed and the telephone pole it is mounted to, located in the vicinity of the gazebo, will be removed. The electrical connections and meter box will be relocated in a marine-rated closet installed in the landscape bed surrounding the gazebo. In this position, the box would not really be below ground but rather in the well-drained landscaping soil, surrounded by landscaping, essentially screened from public view.

### Activities to be funded by Community Connectivity grant

- Renovation and installation of pedestrian paths through the Town Green as depicted on the site plan prepared by Anchor Engineering Services. The subsurface will be improved with a processed gravel and graded to drain. The surface will be finished with a stone dust / crushed granite to match the material currently in place.
- Twelve (12) new, period-appropriate, re-creation, 12-14' post-mounted lights with electrical outlets

Existing Old Boston Fixture: [Old Boston Fixture 2.pdf](#)

Examples of existing fixtures used in the area:



Sparrow Commons at 119/123  
Broadway St, Colchester



11 Hayward Avenue



Hebron Town Hall and Main Street

Proposed six (6) sided vintage fixture: <https://www.sternberglighting.com/gettysburg-9920-vcob/>

[https://www.gotitwholesale.com/vintage-municipal-quality-street-light-package-giws?gclid=EA1aIQobChMIhMPdwM6Y6gIVAwilCR3w4A7vEAQYCiABEgJ6xPD\\_BwE](https://www.gotitwholesale.com/vintage-municipal-quality-street-light-package-giws?gclid=EA1aIQobChMIhMPdwM6Y6gIVAwilCR3w4A7vEAQYCiABEgJ6xPD_BwE)

Proposed eight (8) sided vintage fixture: <https://www.sternberglighting.com/parkway-8603led/>  
<https://www.nilandco.com/product-categories/post-top-luminaires-tenon-mount/dubuque-series/db-led-d4>

Proposed four (4) sided vintage fixture: <https://www.sternberglighting.com/state-9403led/>

- New Bus Shelter (see attached)
- Installation of new benches

Existing for consistency: <https://www.sitescapesonline.com/westport-wp1-1010.asp>

Proposed but very expensive: <https://klynchandsons.com/central-park-settee/>

Proposed compromise: <https://www.theparkcatalog.com/aluminum-victorian-park-bench>

- Purchase of trash receptacles (<https://www.sitescapesonline.com/cityview-cv2-2100.asp>)
- Replacement of Wooden Event Board (in-kind)

**Activities not funded by grant**

- Remove old Public Address system, telephone pole and light. Install marine-rated electrical service box to house equipment currently located in shed.

**List of Attached Exhibits**

**Site Plan and Architectural Rendering**

Layout, Drainage & Grading Plan – Anchor Engineering Services – 10/28/2019, Revised 12/3/2020

Proposed Bus Shelter Renderings 1 & 2 – Brewster Architects – August 3, 2018

**Materials**

Central Park Settee Drawing

**Photos**

Main Path

Former Bus Shelter

Historic Light Post Photo

Old Boston Fixture

Existing Park Bench

Existing Electrical Cabinet and Utility Pole

Existing Community Events Board



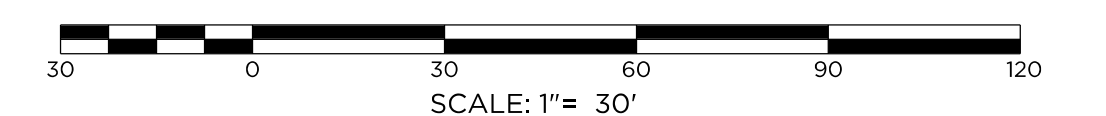
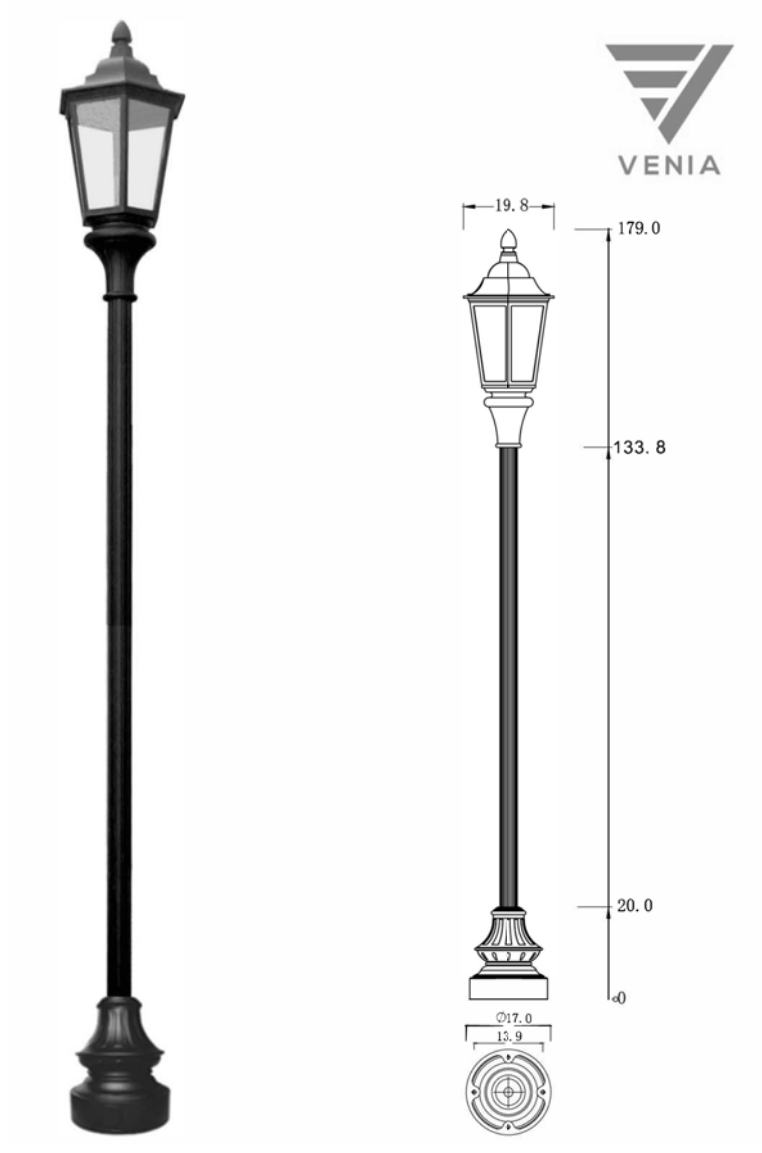
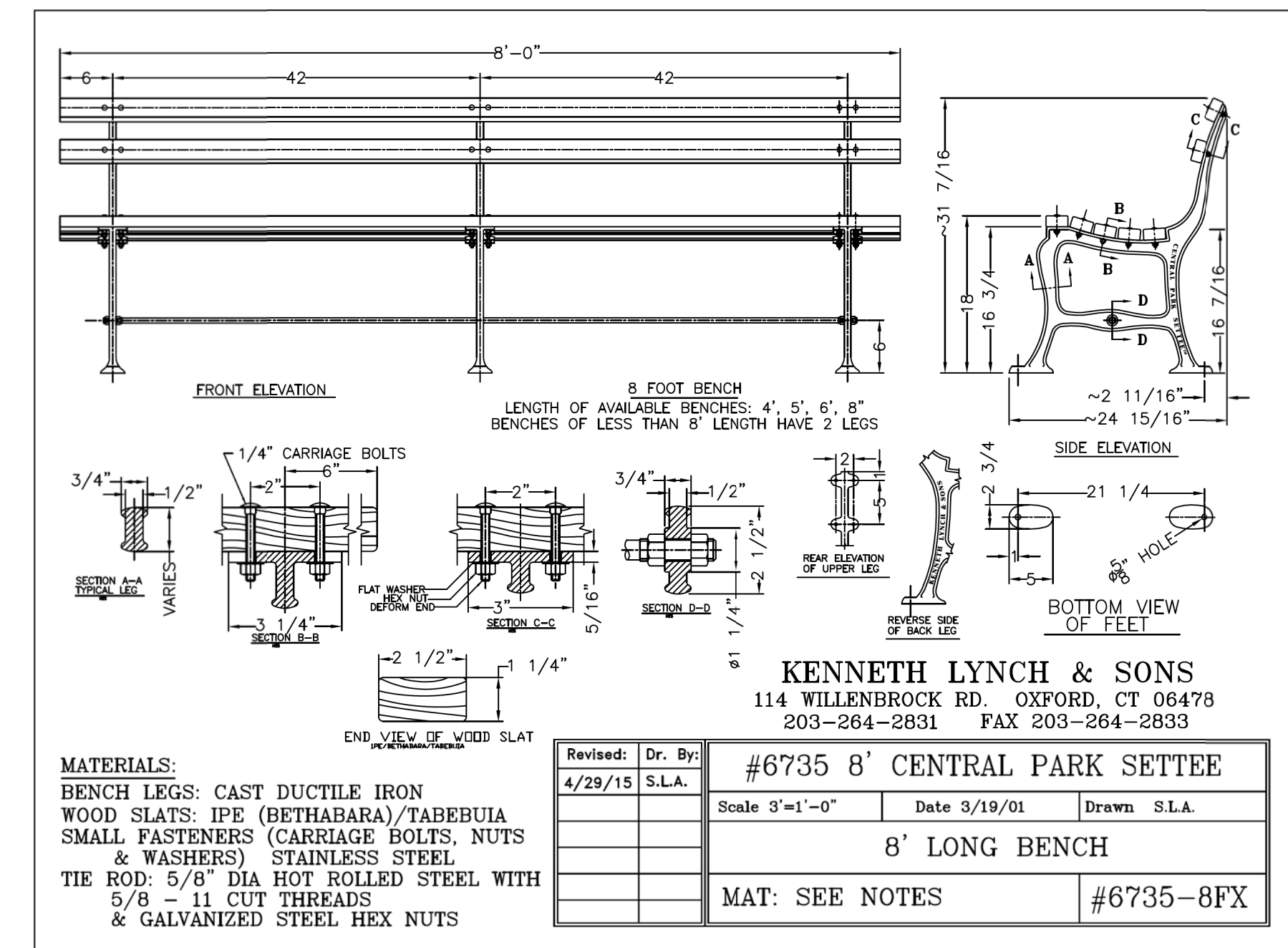
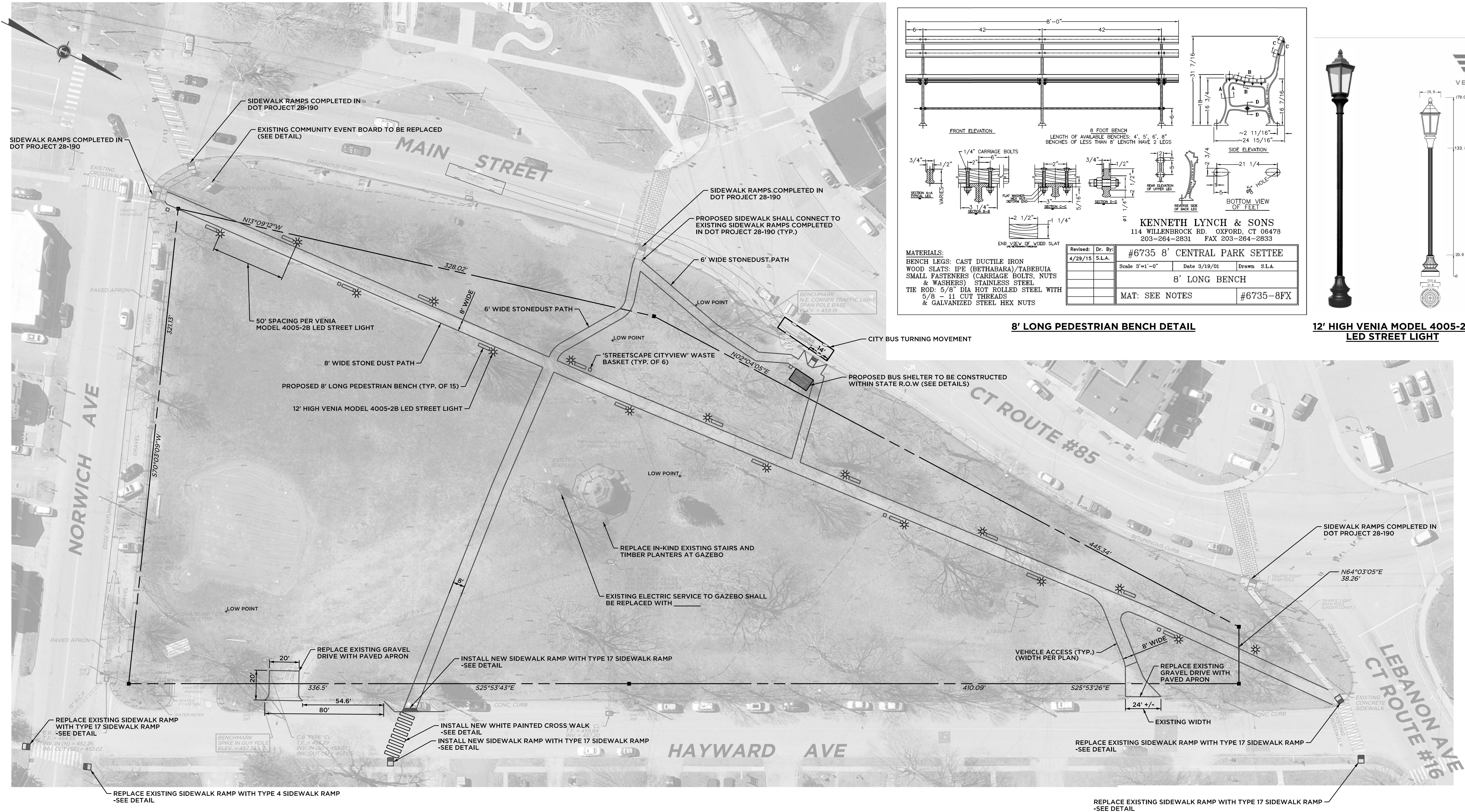

**ANCHOR ENGINEERING SERVICES, INC.**  
 41 Sequin Drive  
 Glastonbury, CT 06033  
 Phone: (860) 633-9770  
 Fax: (860) 633-5971  
 www.anchorengr.com

Civil Engineering • Environmental Consulting • Land Surveying • Construction Management

PROJ. ENGINEER: MJP  
 PROJ. MANAGER: KRG  
 OFFICE REVIEW: KRG

PREPARED FOR  
 TOWN OF COLCHESTER

**LAYOUT, GRADING & DRAINAGE PLAN**  
**CCGP - TOWN GREEN IMPROVEMENTS**  
 NORWICH AVENUE (RTE. 616) COLCHESTER, CT

REVISIONS	
12/02/20	

PROJECT	DATE	SHEET NO.	OF
084-17	10/28/19	2	4

SCALE: 1" = 30'



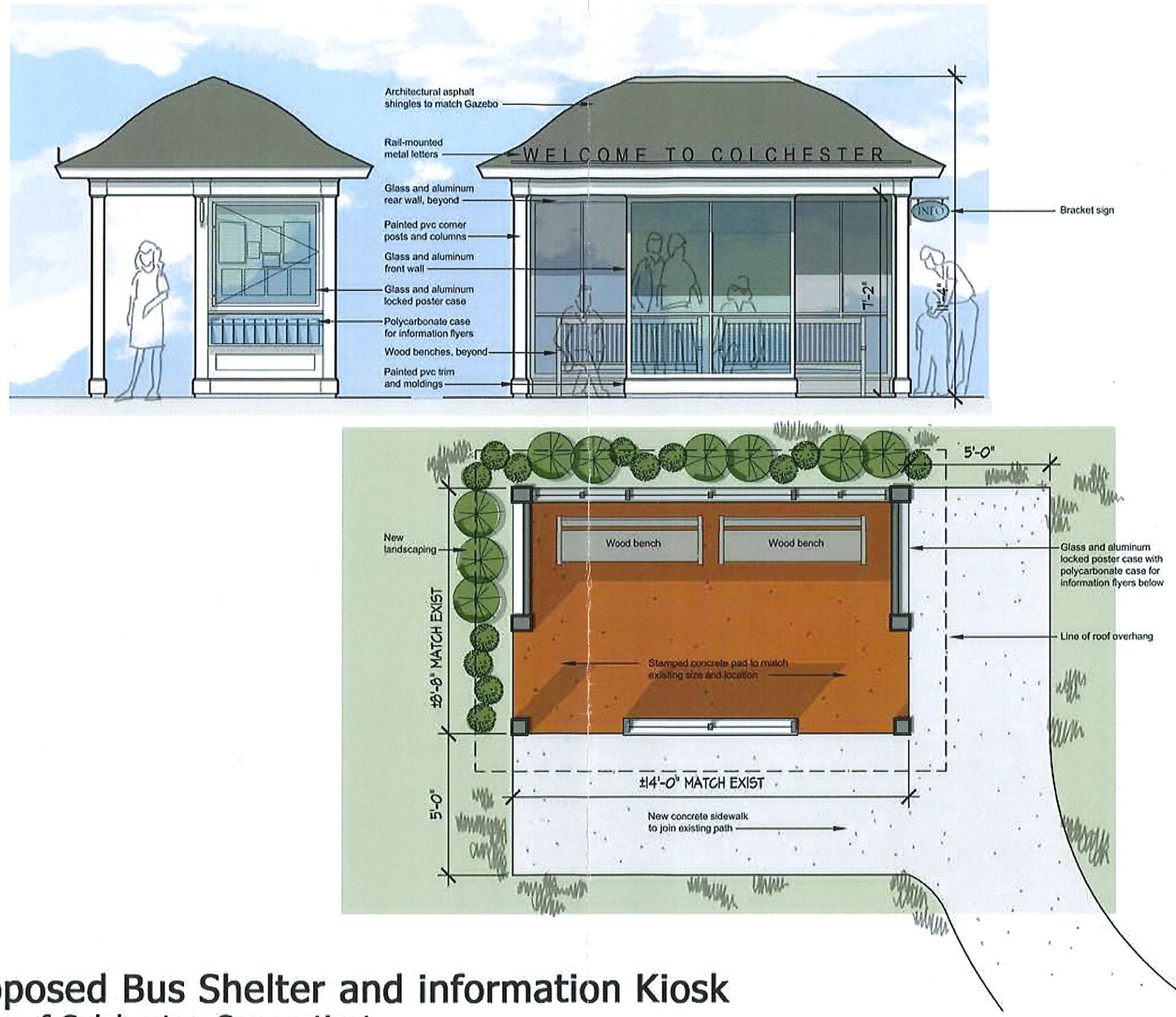

**Proposed Bus Shelter and information Kiosk**  
 Town of Colchester, Connecticut

August 03, 2018





Proposed Bus Shelter and information Kiosk  
Town of Colchester, Connecticut

August 03, 2018

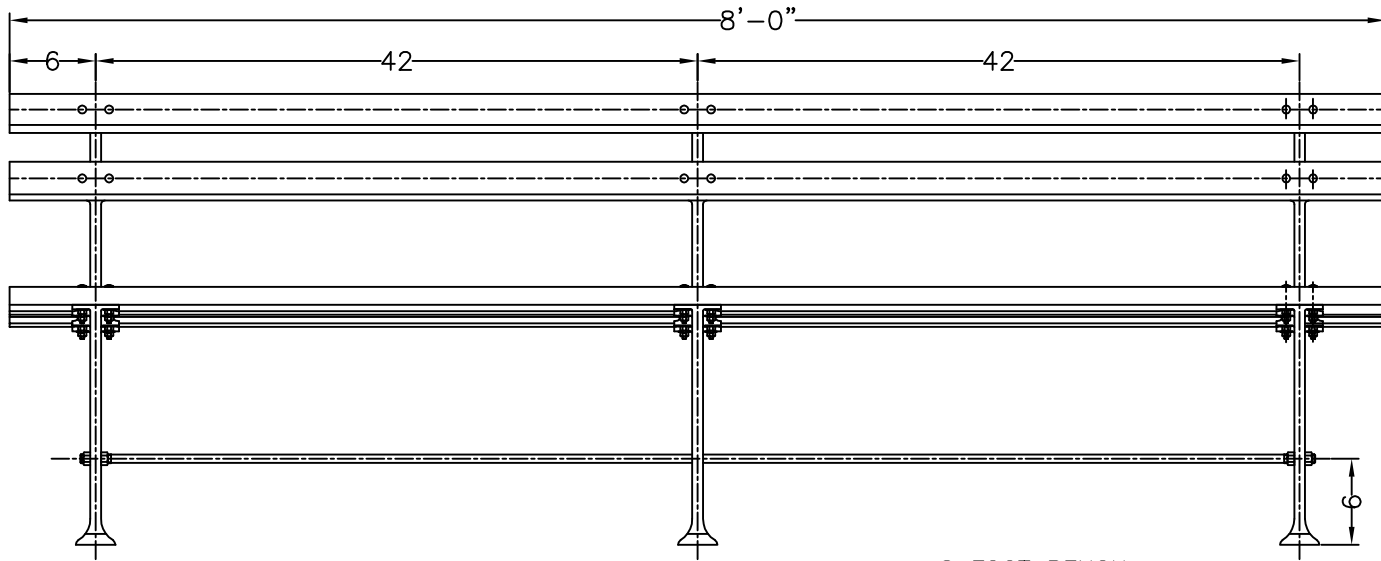

FRONT ELEVATION

8 FOOT BENCH

LENGTH OF AVAILABLE BENCHES: 4', 5', 6', 8'  
BENCHES OF LESS THAN 8' LENGTH HAVE 2 LEGS

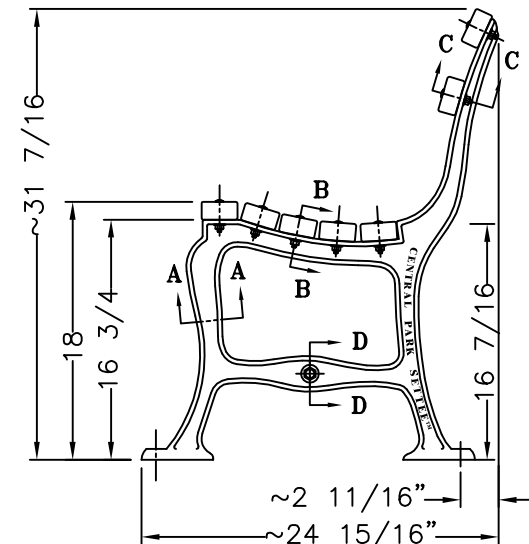

SIDE ELEVATION

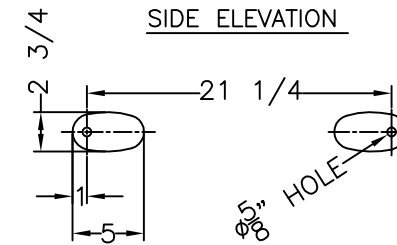
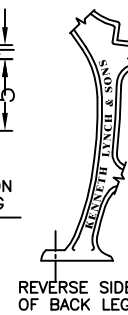
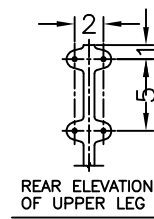
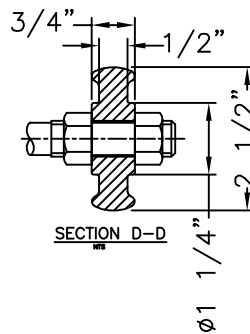
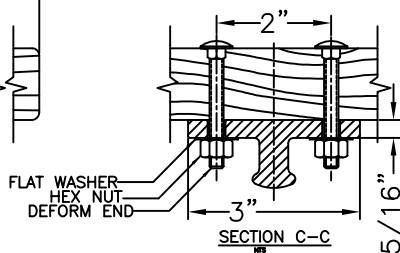
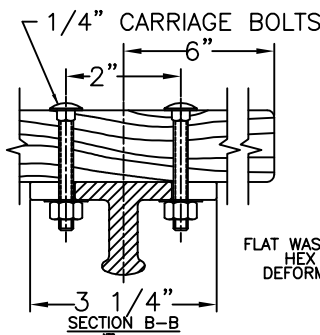
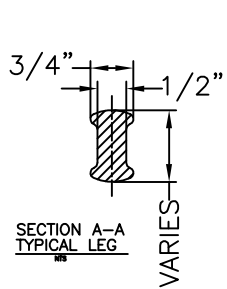

BOTTOM VIEW OF FEET

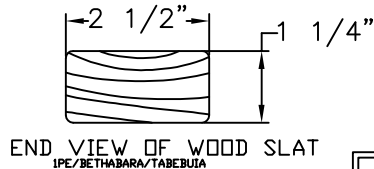

**KENNETH LYNCH & SONS**

114 WILLENBROCK RD. OXFORD, CT 06478  
203-264-2831 FAX 203-264-2833

**MATERIALS:**

BENCH LEGS: CAST DUCTILE IRON  
WOOD SLATS: IPE (BETHABARA)/TABEUUA  
SMALL FASTENERS (CARRIAGE BOLTS, NUTS & WASHERS) STAINLESS STEEL  
TIE ROD: 5/8" DIA HOT ROLLED STEEL WITH 5/8 - 11 CUT THREADS & GALVANIZED STEEL HEX NUTS

Revised:	Dr. By:	#6735 8' CENTRAL PARK SETTEE	
4/29/15	S.L.A.	Scale 3'=1'-0"	Date 3/19/01
		Drawn S.L.A.	
		8' LONG BENCH	
		MAT: SEE NOTES	#6735-8FX











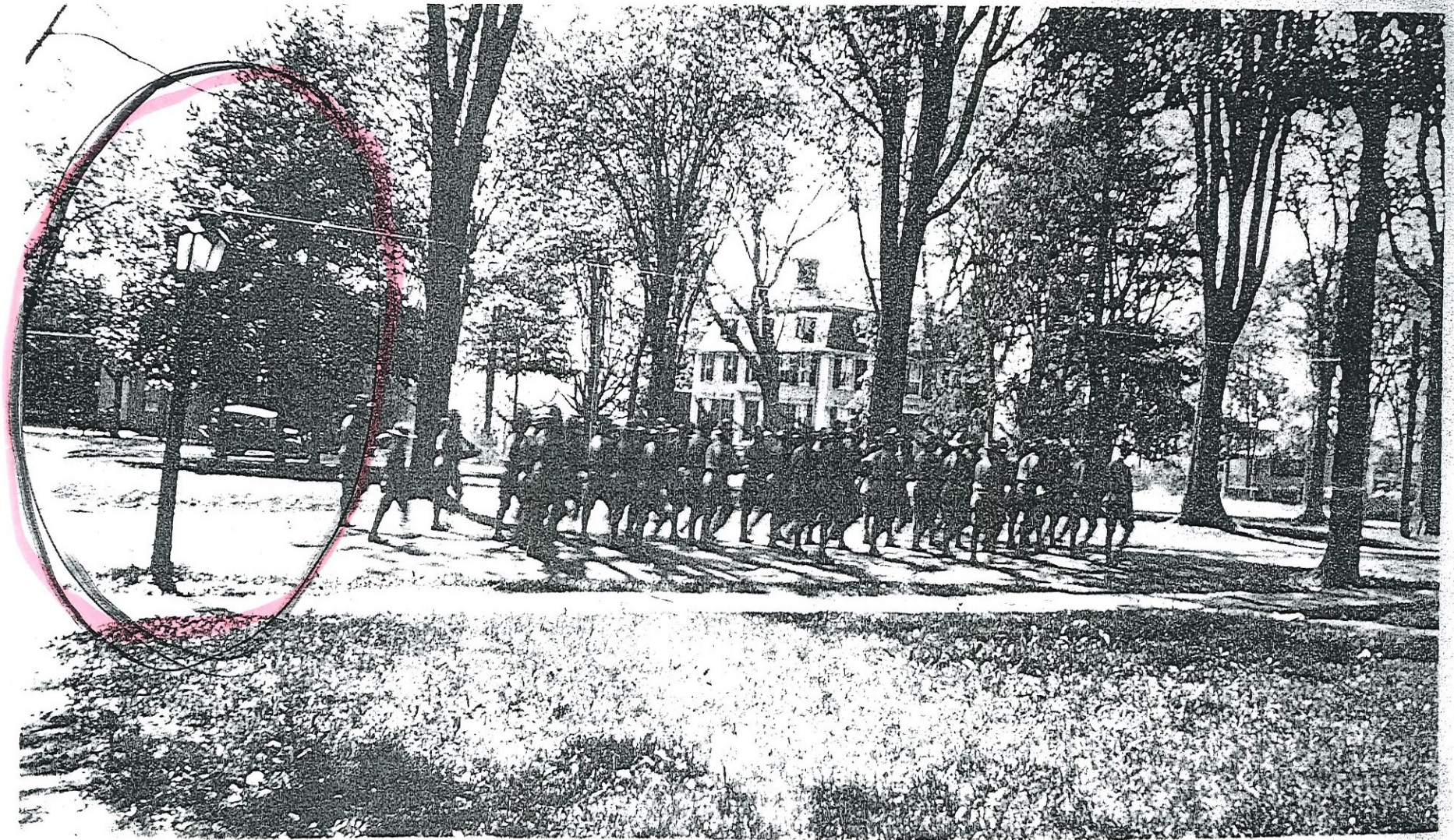

View of soldiers in maneuvers on the Town Green with the Jonathan Deming residence in background.

Present Location: ~~Noel's Grocery~~, corner of Broadway and Main Street.





# Old Boston Post Top (V092)

## Old Boston, 150 HPS, Type III Horizontal

Old Boston, 150 HPS, Type III Horizontal

The Philips Hadco Old Boston post top family offers a simple modern take on the traditional lantern, providing style and elegance to downtown areas, commercial developments, parks and residential communities. The Old Boston offers a range of optical distributions and panel globes to suit any application.

### Product data

General Information		Commercial Code	
Lamp Source Code	HPS	Commercial Code	V092-15S3H
Lamp Watts	150	Order code	V092-15S3H
Photometric Distribution Type	Type III	Catalog Number Description	Old Boston, 150 HPS, Type III Horizontal
		Service / Spec Smart	-
		Material Nr. (12NC)	HAD70000701
Operating and Electrical			
Voltages	120/208/240/277/347 V		
Product Data			
Order product name	Old Boston, 150 HPS, Type III Horizontal		













CONGRATULATIONS  
GRADUATE

TOGETHER  
#Cohesive